

NY-EL SERIES**NEW YORK CITY APPROVED EMERGENCY LIGHT****OVERVIEW**

The NY-EL Series steel emergency light is approved for use throughout New York City's five boroughs. It features a rugged 20-gauge steel housing finished in a white powder coat. The NY18 features (2) top-mounted 9W lamp heads.

The NY-EL has a 90-minute emergency run time; this sturdy fixture is ideal for many commercial environments including schools, warehouses, apartment buildings, and government institutions. The NY-EL surface mounts in a number of different ways to a variety of surfaces and features conduit knockouts on either side of the unit making installation simple.

EXTERNAL SPECIFICATIONS

The 20-gauge steel enclosure provides a secure environment for the battery and circuitry of the unit while the lamp heads are mounted securely to the top of the fixture. Custom colored finishes are available for an additional charge, call or email to inquire.

INTERNAL SPECIFICATIONS

The NY-EL is configured with universal 120/277VAC input and solid state charging circuitry. Low voltage disconnect, AC lockout, and brownout protection are included standard.

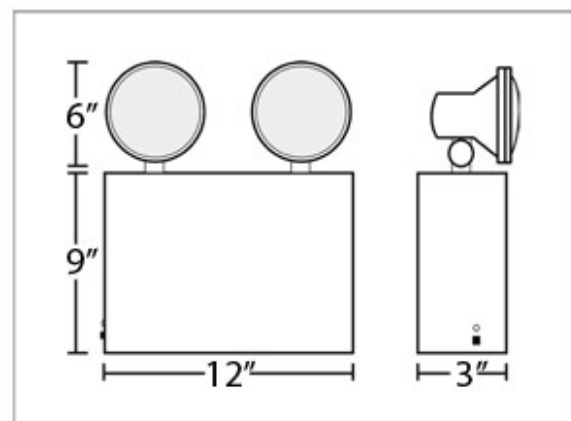
DIMENSIONS

LAMP SPECIFICATIONS

9-watt, PAR36 lamps are standard. Comes with (3) lamp heads but can also be ordered with one; or no lamps at all. When ordered with no lamps the unit is essentially a remote power supply for remotely located lamp fixtures.

BATTERY SPECIFICATIONS

This NYC Approved emergency light is outfitted with a maintenance free, sealed valve regulated lead calcium battery. The battery features a 24-hour recharge time and provides 90-minutes of emergency run time for the standard 6V 18W model with 9W lamp heads. Comes standard with a current charge regulator.

WARRANTY

The NY-EL Series comes with a three-year factory warranty. The lamps are not covered. Deliberate damage, misuse, or improper installation effectively cancel the warranty. Battery features a 20% per year pro-rata warranty.

INSTALLATION

NYC Approved steel emergency lights are for indoor installation onto normally inflammable surfaces. They are designed for heavy-duty applications that do not feature direct contact with moisture or corrosive agents.

The NY-EL Series is suitable for wall mounting and features side and back conduit knockouts. The unit comes with detailed instructions for installation.

Connect either 120 or 277V AC power into the unit, connect the battery, and let the fixture charge for 24 hours.

CODE COMPLIANCE

NEW YORK CITY APPROVED by the Department of Buildings. The NY18 Series emergency light is compliant with building and fire code regulations throughout the United States and Canada. UL 924 Listed. NFPA 101 Life Safety Code, NEC, ICC, IBC, Damp Location Approved.



ORDERING INFORMATION

Series and Type

NY-EL-6-27-3H (NYC Approved Emergency Light with (3) 6V 9W Tungsten lamps)